

MODEL

HG



ORBINOX
VALVE SOLUTIONS IN MORE THAN 70 COUNTRIES

INSTALLATION, OPERATION & MAINTENANCE MANUAL

HG Knife Gate Valve



SPAIN · UK · GERMANY · FRANCE · CANADA · USA · BRAZIL · CHILE · PERU · INDIA · CHINA

www.orbinox.com

INSTALLATION, OPERATION & MAINTENANCE MANUAL

HG Knife Gate Valve

- 0. INTRODUCTION
- 1. HANDLING
- 2. INSTALLATION
- 3. ACTUATORS
 - 3.1. Handwheel
 - 3.2. Bevel gear
 - 3.3. Pneumatic
 - 3.4. Electric
 - 3.5. Hydraulic
- 4. MAINTENANCE
 - 4.1. Packing seal replacement
 - 4.2. Sealing sleeves replacement
 - 4.3. Lubrication
- 5. STORAGE
- 6. ENVIRONMENTAL CONSIDERATIONS
- 7. PARTS LIST & DRAWING

0. INTRODUCTION

The HG model knife gate is a full flange valve designed for a wide range of industrial applications. The double-seated design provides bi-directional shut off. The design of the valve body and the two rubber sleeves (3) makes the HG valve well suited for handling abrasive slurries.

The two sleeves (3) are in permanent contact with each other when the valve is open. While the valve is either open or closed, the media does not encounter the interior of the body. Minimal leakage may occur from the bottom of the valve during opening and closing cycles.

Some leakage will occur from the bottom of the valve during operation. This allows solids to be flushed from the body cavity and will ensure the full stroke of the valve.

General recommendations:

- The HG valve is recommended for slurry applications where resistance to abrasion and erosion is critical. Slurry is defined as a liquid with relatively small particles, held in suspension.
- The HG valve is not recommended in applications where erosion/abrasion is not critical.
- The lower splash guard must be adapted to the discharge system using the connections supplied to avoid accumulation of solid materials that might damage the sleeves. This solution is strongly recommended in applications with fluids that are very corrosive.
- Discharge from HG valves must be taken into consideration when exposure would be hazardous to personnel or to the environment. Safety precautions, such as splash guard, must be utilized to redirect the hazardous discharge to a safe location.

The HG valve complies with the following European directives:

- Machinery Directive

When applicable it can also comply with the following additional directives:

- Pressure Equipment Directive
- Potentially Explosive Atmospheres (ATEX)

It is the user's liability to verify the maximum working conditions (PS, TS), medium (gas or liquid) and dangerousness group (1 or 2) and if the fluid is unstable to properly classify the valve according the PED directive.

ORBINOX offers, supplies and certifies valves according to the information received from the customer. The customer is liable to make sure this information is accurate and according to specific working conditions requirements where the valve will be installed.

**For EU Directives and other Certificates, please see the document:
Directives & Certificates Compliance - Knife Gate Valves - IOM**

1. HANDLING

The valves are packed according to the appropriate transport standards. If you receive the packing damaged, please inform the transport company in writing and contact your ORBINOX representative.



When handling an ORBINOX valve please pay attention to the following points:

- **DO NOT ATTACH LIFTING GEAR TO THE VALVE ACTUATORS OR GATE GUARDS.** They are not designed to bear the weight and could easily be damaged.
- **DO NOT LIFT THE VALVE BY THE VALVE BORE.**
This can cause damage to the seating surfaces and seals.
- Check that selected lifting gear is rated to carry the weight of the valve. The valve can be handled using eyebolts, soft straps or slings.
- **EYEBOLTS:** make sure the eyebolts have the same thread as the bolt holes and they are all well secured. Ideally when using lifting gear to move an ORBINOX valve, it should be supported by two or more eyebolts screwed into the tapped fixing holes in the valve body.
- **SOFT STRAPS:** with the valve in the closed position, the straps should be placed between the gland area and the bore such that the valve is balanced.

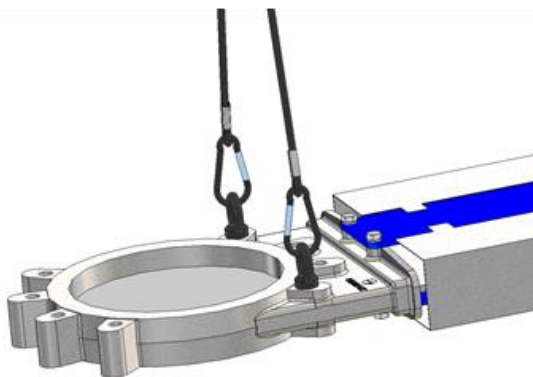

Fig. 1 Handling with eyebolts

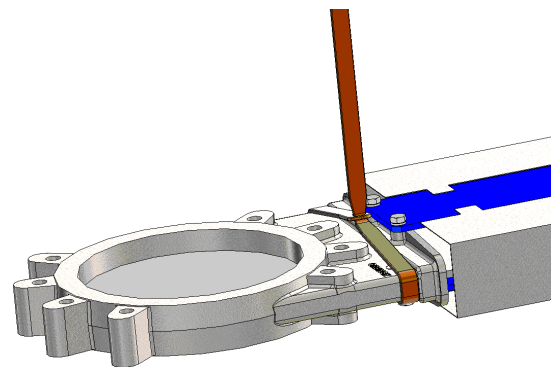
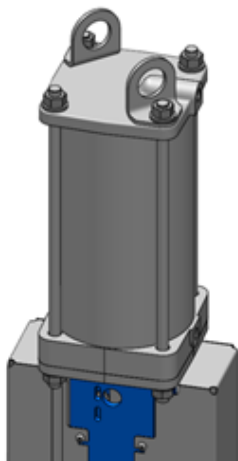

Fig. 2 Handling with soft straps

PNEUMATIC ACTUATED VALVES (Non-standard valves shall be checked case by case)

ORBINOX pneumatic valves (with $\varnothing 125$ cylinder and above) are supplied with 2 lifting lugs for a safe handling of the valve for vertical movements



Handling WARNING:

Lifting lugs are not machined so they could have sharp corners; soft straps or slings are forbidden to be used with these lifting lugs

Below table shows the maximum weight of valve + pneumatic cylinder that 2 lifting lugs can hold depending on lifting chain angle (X):

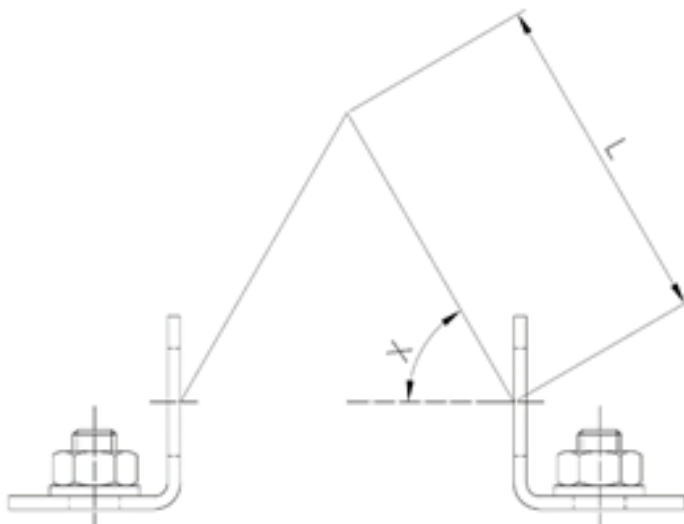

CYLINDER	With 2 lifting lugs: max. weight valve + cylinder (kg.)			
	L: minimum lifting chain length			
	X: 60°		X: 75°	
	Kg.	Lmin (mm)	Kg.	Lmin (mm)
125	170	130	310	220
160	270	170	500	280
200	390	220	710	380
250	740	300	1335	500
300	1140	360	2030	600
350	1615	440	2835	720
400	2105	500	3660	830

- For horizontal movement, the valve shall be lifted mainly from the body and the yoke. See above instructions for further instructions
- Cylinder's lifting lugs can only be used during horizontal movement of the valve to help balance the valve given the weight is hold at the body lifting point (center of gravity is approx. centered on the body)
- The valve can be lowered from vertical to horizontal position when it is hanging from the cylinder's lifting lugs

2. INSTALLATION

**For EU Directives and other Certificates, please see the document:
Directives & Certificates Compliance - Knife Gate Valves - IOM**



In order to avoid personal injury or damage to property when handling and installing the valve, it is important to observe the following warnings:

- It is the User's responsibility to verify compatibility of valve parts materials with the internal fluid
- Qualified and trained personnel must carry out the handling and maintenance of the valve
- Use suitable Individual Protection Equipment (IPE) (gloves, safety footwear...)
- Disconnect all lines affecting the valve and put up a notice notifying that work is being carried out on the valve
- Isolate the valve completely from the process
- Release process pressure
- Drain the fluid from the valve

Before installation, inspect the valve body and components for any damage that may have occurred during shipping or storage. Make sure the internal cavities within the valve body are clean. Inspect the pipeline and mating flanges, making sure the pipe is free of foreign material and that the flanges are clean.



The valve is bi-directional, and consequently permits installation without considering the flow direction. **Always install and keep the valve in the fully open position until it starts normal operation.**

Special care should be taken to maintain the correct distance between the flanges and to ensure that they are parallel to the valve body.

Use caution to not cause damage to the sleeves by forcing the valve into an opening that is too narrow when the valve is being positioned between the pipe flanges. It is possible to use a lubricant (non-petroleum-based lubricant such as silicone or ordinary liquid soap) to help slip the valve between the pipe flanges.

Incorrect alignment of the valve can cause deformations, which can lead to difficulties in operation.

The following table gives the different valve face to face requirements before and after installation.

Dimensions (Metric)

DN		80	100	150	200	250	300	350	400	450	500	600	700	750	800	900
Face to face	Before installation	183	183	186	192	233	264	264	287	319	367	380	383	405	479	479
	After installation	175	175	178	184	225,5	257	257	279	311	359	371	373	395	467	467

Dimensions (Imperial)

DN		3	4	6	8	10	12	14	16	18	20	24	28	30	32	36
Face to face	Before installation	7.20	7.20	7.32	7.55	9.17	10.39	10.39	11.29	12.55	14.44	14.96	15.08	15.94	18.85	18.85
	After installation	6.88	6.88	7	7.24	8.89	10.11	10.11	11	12.24	14.13	14.62	14.68	15.55	18.38	18.38

Additional flange gaskets are not required as the outer face of the sleeve behaves as a gasket against the pipe counter flange to provide a tight seal.

Enough space should be left between the flanges to permit ease of movement for the valve gate with sleeves installed, without damaging them.

The following table shows recommended torque values for the valve flange bolts:

Dimensions (Metric)

DN (mm)	T (mm)	PN-10 (EN 1092-1)	Torque (N.m)
80	39	M16	70
100	39	M16	70
150	42	M20	140
200	45	M20	140
250	47	M20	140
300	52	M20	140
350	57	M20	140
400	61	M24	235
450	63	M24	235
500	67	M24	235
600	72	M27	350
700	72	M27	350
750	-	-	-
800	80	M30	470
900	84	M30	470

Dimensions (Imperial)

DN (inch)	T (in)	CL150 (ASME B16.5/B16.47 Series A)	Torque (Ft/Lbs)
3"	1 1/2"	5/8" - 11 UNC	52
4"	1 1/2"	5/8" - 11 UNC	52
6"	1 1/2"	3/4" - 10 UNC	103
8"	1 3/4"	3/4" - 10 UNC	103
10"	1 3/4"	7/8" - 9 UNC	103
12"	2"	7/8" - 9 UNC	103
14"	2 1/4"	1" - 8 UNC	103
16"	2 1/4"	1" - 8 UNC	173
18"	2 1/2"	1 1/8" - 7 UNC	173
20"	2 1/2"	1 1/8" - 7 UNC	173
24"	2 3/4"	1 1/4" - 7 UNC	258
28"	2 3/4"	1 1/4" - 7 UNC	258
30"	4"	1 1/4" - 7 UNC	258
32"	3"	1 1/2" - 6 UNC	347
36"	3 1/4"	1 1/2" - 6 UNC	347

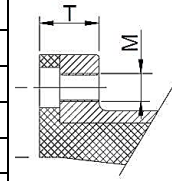

Dimensions (Imperial)

DN (inch)	T (in)	CL300 (ASME B16.5/B16.47 Series A)	Torque (N.m)	Torque (Ft/Lbs)
3"	1 1/2"	3/4" - 10 UNC	70	52
4"	1 1/2"	3/4" - 10 UNC	70	52
6"	1 1/2"	3/4" - 10 UNC	140	103
8"	1 3/4"	7/8" - 9 UNC	140	103
10"	1 3/4"	1" - 8 UNC	140	103
12"	2"	1 1/8" - 7 UNC	140	103
14"	2 1/4"	1 1/8" - 7 UNC	140	103
16"	2 1/4"	1 1/4" - 7 UNC	235	173
18"	2 1/2"	1 1/4" - 7 UNC	235	173
20"	2 1/2"	1 1/4" - 7 UNC	235	173
24"	2 3/4"	1 1/2" - 6 UNC	350	258
28"	2 3/4"	1 5/8" - 8 UN	350	258
30"	4"	1 3/4" - 5 UNC	350	258
32"	3"	1 7/8" - 8 UN	470	347
36"	3 1/4"	2" - 4.5 UNC	470	347

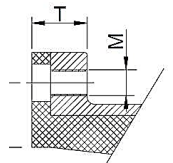

Select the recommended torque based on bolt size for other flange drilling patterns. Make sure that cross-pattern tightening sequence is always followed.

The valve can be mounted in any position regarding the pipe. However, it is advisable to place it vertically in horizontal pipeline (A) if the installation allows it. (Please consult the technical department at ORBINOX).

With larger diameters (> 300 mm/>12"), heavy actuators (pneumatic, electric, etc.), or with the valve installed horizontally (B) or at an angle (C) on a horizontal pipeline, the installation will require the construction of suitable supports. (See the following diagram and consult the technical department at ORBINOX).

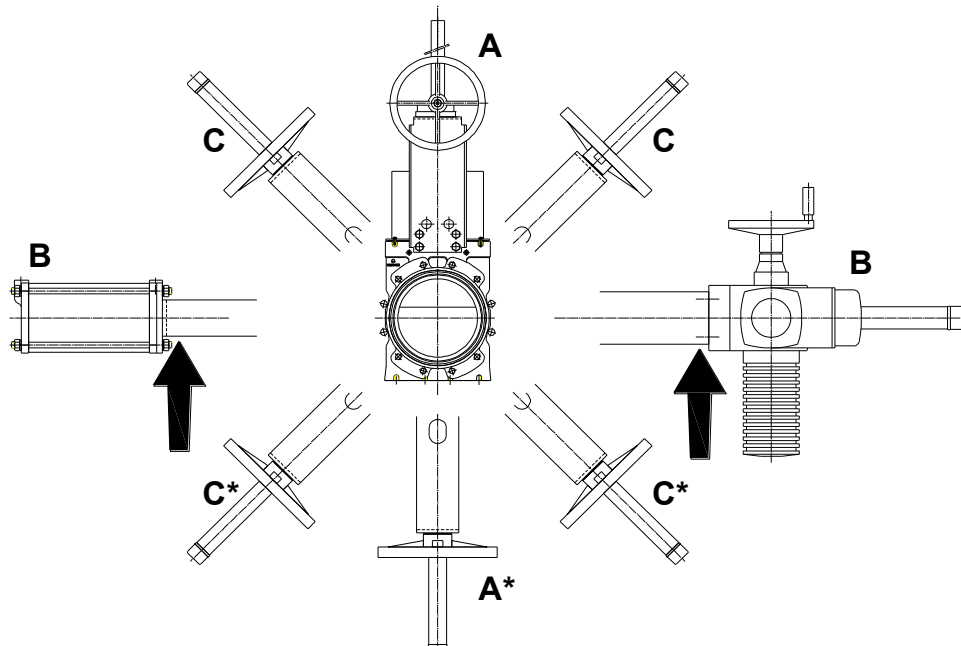

** For these positions please consult ORBINOX*

The installation of suitable supports is advised when significant vibrations coming from the piping are present.

In vertical pipelines, the construction of suitable supports is always required (for further information please consult the technical department at ORBINOX).

The HG valve shall be installed between flanges. A counter flange is needed for a dead-end service.

Once the valve is installed, test that the flanges have been fastened correctly and that all electrical and/or pneumatic connections have been properly made.

Valves installed in an orientation with the actuator in or below horizontal may require flushing to prevent the build-up of solids in the cavity. (Please consult the technical department at ORBINOX).



IMPORTANT. Valves equipped with flushing shall also be equipped with a conventional leak proof packing and a lower splash guard.

The operation of automated valves is limited only with fitted gate covers (Optional in North America).

First, operate the valve with no flow in the pipeline. Then test operation and valve seal with flow running. During start up, make sure that there is no excess in the pipes. Once performance has been tested, the valve can be put into operation.

All valves are delivered pre-treated with silicone lubricant. Prior to putting into service, check that the valve has been well lubricated. All valves are equipped with a lubrication device.

It should be noted that the packing material might settle in shipping/storage, which can cause minor leakage. This can be solved by tightening the gland follower (5) during installation. The nuts should be tightened gradually and crosswise until the leakage stops (see the next figure). Check that there is no metal contact between the gland follower (5) and the gate (2).

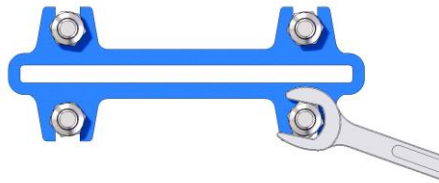

If the gland follower nuts are over torqued, the force needed to operate the valve will increase, the valve function will be affected and the box packing lifetime will be shortened.

The table below shows the recommended maximum torques for the gland follower nuts.

DN (mm)	Torque (N.m)
80 - 200	15
250 - 300	25
350 - 600	30
700 - 900	35

DN (inch)	Torque (Ft/Lbs)
3" - 8"	11
10" - 12"	18
14" - 24"	22
28" - 36"	26

IMPORTANT. The splash guard must be adapted to the discharge system using the connections supplied to avoid accumulation of solid materials that might damage the sleeves and foul the valve.



ATTENTION: DO NOT CLOSE BOTH ENDS OF THE LOWER PLATE



Once performance has been tested, the valve can be put into operation.

Approximate weight of the handwheel-operated valve (rising stem):

Dimensions (Metric)

DN (mm) : kg			
DN 80: 33 kg	DN 250: 195 kg	DN 450: 578 kg	DN 800: 1575 kg
DN 100: 42 kg	DN 300: 312 kg	DN 500: 800 kg	DN 900: 2085 kg
DN 150: 67 kg	DN 350: 340 kg	DN 600: 915 kg	
DN 200: 148 kg	DN 400: 440 kg	DN 750: 1370 kg	

Dimensions (Imperial)

DN (inch) : lbs			
DN 3: 73 lbs	DN 10: 430 lbs	DN 18: 1274 lbs	DN 32: 3472 lbs
DN 4: 92 lbs	DN 12: 687 lbs	DN 20: 1763 lbs	DN 36: 4597 lbs
DN 6: 148 lbs	DN 14: 749 lbs	DN 24: 2017 lbs	
DN 8: 326 lbs	DN 16: 970 lbs	DN 30: 3020 lbs	

3. ACTUATORS

**For EU Directives and other Certificates, please see the document:
Directives & Certificates Compliance - Knife Gate Valves - IOM**

3.1. HANDWHEEL

To open the valve, turn the handwheel counter clockwise. To close, turn the handwheel clockwise.

3.2. BEVEL GEAR

Bevel gear designed to get a pull force below 30 Kg.

To open the valve, turn the handwheel (10) counter clockwise. To close, turn the handwheel clockwise.

3.3. PNEUMATIC

Valves are usually supplied with a double acting pneumatic actuator although, upon request, we can supply single-acting actuators. In either case the feed pressure can vary between 3,5 and 10 bar. However, the size of the actuator for each valve has been designed for a feed pressure of 6 bar.

It is essential for a good maintenance of the cylinder that air should be well dried, filtered and lubricated. Air quality shall fulfil the following requirements:

- ISO 8573-1 Grade 5:4:3 for regular process (ON / OFF services).
- ISO 8573-1 Grade 5:3:3 for regular process at low temperature (-20 °C).
- ISO 8573-1 Grade 3:4:3 for cylinders with positioners.
- ISO 8573-1 Grade 3:3:3 for cylinders with positioners at low temperature (-20 °C)

It is recommended to actuate the cylinder 3-4 times before the start up, once it is installed in the pipeline.

3.4. ELECTRIC ACTUATOR

Depending on the type or make of the electric actuator, specific instructions (i.e. a manufacturer's manual) will be supplied.

Open/close limit switches setting

1. When operating the valve stand clear of any moving parts such as the stem and /or gate assembly.
2. Maximum travel speed of the gate must equal or below 25 mm/s (1 in/s).
3. Care should be taken to ensure that electrical motors are wired correctly to the power source. Incorrect phasing of 3-phase wiring may cause valve/motor damage.
4. Open and close positions of VG valves shall be controlled by means of the motor limit switches. Do not use the motor torque settings to control the valve position.
5. Close position setting. Operate the valve manually to the fully close position until the end of the gate is at the "A" distance and set the close limit switch. See below figure.

DN (mm/")	A (mm)	A (in)
80/3"	45,5	1.79
100/4"	54	2.12
150/6"	52	2.05
200/8"	54	2.12
250/10"	53	2.09
300/12"	55	2.16
350/14"	72	2.83
400/16"	73	2.87
450/18"	75	2.95
500/20"	65	2.56
600/24"	70	2.75
800/32"	35	1.38
900/36"	30	1.18

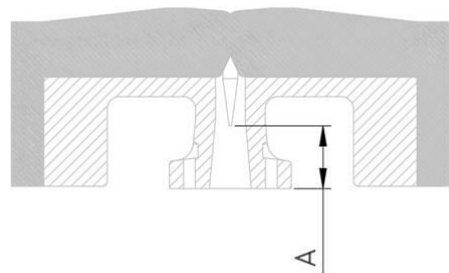

6. Open position setting. Operate the valve to the fully open position until the gate moves the distance "Y" as shown in figure below and set the open limit switch.

DN (mm/")	Y (mm)	Y (in)
80/3"	115	4.5
100/4"	140	5.5
150/6"	200	7.9
200/8"	250	9.8
250/10"	315	12.4
300/12"	360	14.2
350/14"	415	15.0
400/16"	465	18.3
450/18"	520	20.5
500/20"	580	22.9
600/24"	700	27.6
800/32"	960	37.8
900/36"	1060	41.7

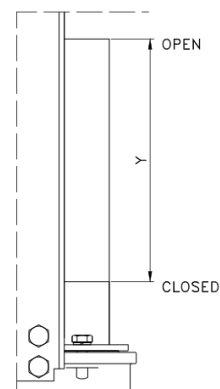

3.5. HYDRAULIC

The valve is sized based on 100bar (1450 PSI) hydraulic supply pressure. The cylinder stroke is a fixed length and does not require any adjustments.

Typically, the actuator travel speed is around 250 mm/min (9.8 in/min) or 0.005 m/s (0.164 in/min).

4. MAINTENANCE

For EU Directives and other Certificates, please see the document: Directives & Certificates Compliance - Knife Gate Valves - IOM

The valve must not undergo any modifications without a previous agreement with ORBINOX. ORBINOX shall not be liable for any damages that may arise due to the use of non-original parts or components



To avoid personal injury or damage to property from the release of process fluid:

- Those in charge of handling and maintenance of the valve must be qualified and trained in valve operations.
- Use appropriate personal protection equipment (gloves, safety shoes, etc).
- Shut off all operating lines to the valve and place a warning sign.
- Isolate the valve completely from the process.
- Release process pressure.
- Drain the process fluid from the valve.

The only maintenance required is to change the packing seal (4) and the two rubber sleeves (3) as well as the use of the grease nipples (7) for regular lubrication.

The life of these elements will depend on the working conditions of the valve such as: pressure, temperature, abrasion, chemical action, number of operations, etc.

To allow optimal operation, the lower part of the valve, accessible through the splashguard (11) should be cleaned regularly.

If the gate is brushed and cleaned regularly, the wear of the sleeves (3) can be minimised.

4.1. Replacement of the packing seal (4):

Depressurise the circuit and place the valve in close position.

1. Remove the gate guards (for automatically actuated valves only).
2. Release the spindle or stem (8) from the gate (2).



Photo 1

3. Loosen the screws of the yoke (6) and remove it (without removing the actuator).
4. Loosen the nuts of the gland follower (5) and remove it. (Photo 3)
5. Remove the old packing rings (4) and clean the stuffing box.
6. Insert the new packing rings (4), making sure that the ring joints alternate (the first on one side of the gate, the next on the other and so on). (Photo 4)
7. Once the necessary packing rings (4) have been inserted, proceed with a steady initial tightening of the gland follower (5) (Photo 3)
8. Reinstall the yoke (6) (with the actuator).
9. Fix the stem (8) to the gate (2).
10. Reinstall the gate guards.
11. Carry out some operations with a loaded circuit and then re-tighten the gland follower (5) to prevent leakage.



Photo 2



Photo 3

4.2. Replacement of the sealing sleeves (3):

1. Remove the valve from the pipeline.
2. Remove the sealing sleeves (3).
3. Set the gate (2) in the open position.
4. Clean within the bodies (1), filling the inner part of the body with silicone-based grease.
5. Lubricate the new sleeves (3) with the same grease (silicone-based) and install them.
6. Reinstall the valve in the pipeline.
7. Tighten the flanges.
8. Operate the valve a couple of times before leaving it in the position required for the process.

4.3. Lubrication:

A silicone-based lubricant is recommended and may be applied using the fittings provided in the body. The gate may also be lubricated by spraying directly.

At a minimum HG valves should be lubricated every 100 strokes for 2" – 10" sizes and every 50 strokes for 12" – 48" sizes. If valves cycle very infrequently, less than once per month, lubrication prior to each stroke is recommended.

Under no circumstances should a hydrocarbon-based lubricant be used.

Twice a year, it is recommended to fill up the stem protector (9) halfway with a calcium-based grease with the following characteristics: highly water resistant, low ash content, and excellent adherence.

As a reference: LUBEKRAFFT® Antiseize 907.

5. STORAGE

Storage recommendations:

- Drain valves of any and all liquid.
- Indoor storage in a well-ventilated, clean and dry room is recommended, to avoid moisture and condensation on the equipment.
- Valves should not be exposed to temperatures higher than 30°C, as some soft seal materials can be damaged when exposed to higher temperatures (sleeves, packing, ...).
- If outdoor storage cannot be avoided, precautions should be taken to keep valves clean and dry. Cover the valve and protect it from sources of heat or direct sunlight.
- During the storage, the valve must always be kept in the open position.
- The only exception is when the valve is supplied with a spring extend (spring to close) cylinder. In this case the valve will be supplied with the gate in the closed position, with the spring cylinder fully extended. **DO NOT STORE** the valve with the spring in a compressed, fully energized position. For storage, it is recommended that the valve sleeves are removed from the valve housing and stored separately from the valve. Reinsert sleeves prior to installation.
- Avoid dirt and/or moisture contamination of the stem.
- To prevent contamination in the supply ports of the cylinders: ensure actuators have appropriate pipe plugs installed.
- The sleeves must be totally relaxed during the storage and without any heavy objects on them.
- Prior to start-up, clean the gate and apply grease according point 4.3. of this manual.
- For all other components installed on the valves, such as electric motors, solenoids, etc., please, consult their respective operational manuals.

6. ENVIRONMENTAL CONSIDERATIONS

- The packaging is made from environmentally friendly materials. Dispose of the packaging through the available recycling channels
- The valve is designed and manufactured with materials that can be recycled by specialised recycling firms. Once the life of the product is expired, you have to consider a proper disposal of the product in order to prevent any negative impact on the environment and allows for the recycling of valuable commodities
- Please follow the local environmental rules in your country for proper disposal

7. PARTS LIST & DRAWINGS

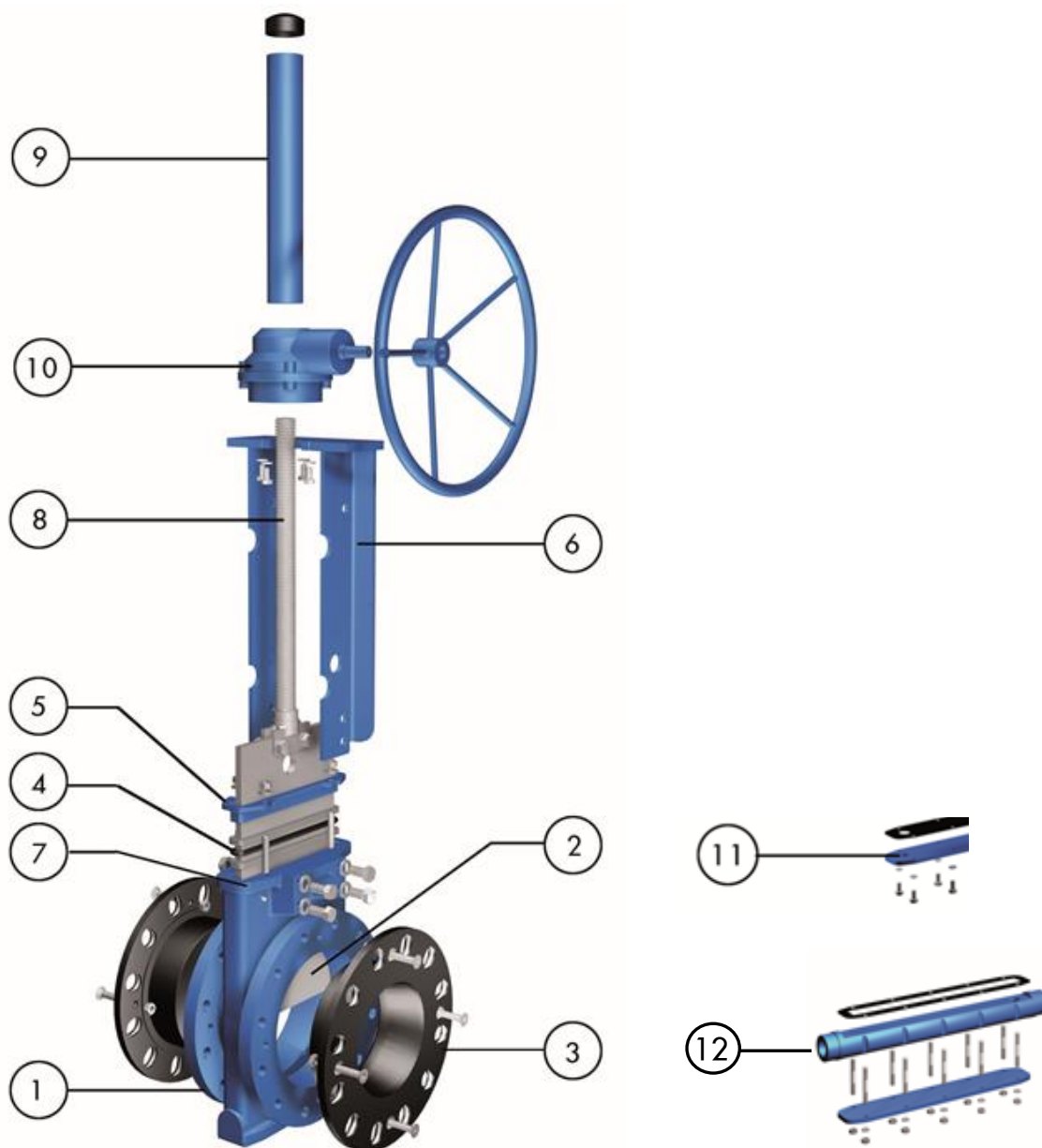

1. BODY	7. GREASE NIPPLE
2. GATE	8. STEM
3. SELEEVES	9. STEM PROTECTOR
4. PTFE PACKING (+EPDM O-ring)	10. BEVEL GEAR
5. GLAND FOLLOWER	11. FLAT PLATE SPLASH GUARD
6. YOKE	12. TUBULAR SPLASH GUARD